

COMENDA BLUELINE LF322

FRONT-LOADING DISHWASHER

A heavy duty dishwasher that is ergonomically designed and comes complete with detergent & rinse aid dispensers for total control of chemical usage.

The LF322 has two wash cycles with durable stainless steel wash arms and double skinned stainless steel doors.



STANDARD FEATURES

- Full stainless steel frame, tank and panels
- Durable stainless steel wash arms
- Inlet and waste hoses included
- Detergent dispenser & rinse aid dispenser
- Guaranteed rinse cycle only when water at 85° C
- Micro filter on wash pump which delivers better wash results
- Heavy duty brass solenoid valve for greater reliability
- Accessories include: 1 peg rack, 1 flatware rack, 1 cutlery container
- Additional options available
- Drain pump
- 1 piece deep drawn wash tank

SPECIFICATIONS ARE SUBJECT TO CHANGE WITHOUT NOTICE.

From the world of Comcater!

National Head Office
156 Swann Drive
Derrimut VIC 3030
Tel: +61 3 8369 4600
Fax: +61 3 8369 4695

Melbourne
96-100 Tope Street,
South Melbourne VIC 3205
Tel: +61 3 8369 4600
Fax: +61 2 8699 1299

Sydney
20/4 Avenue of the Americas
Newington, NSW 2127
Tel: +61 2 9748 3000
Fax: +61 2 9 648 4762

Brisbane
1/62 Borthwick Avenue
Murarrie QLD 4172
Tel: +61 7 3399 3122
Fax: +61 7 3399 5311

COMENDA BLUELINE LF322

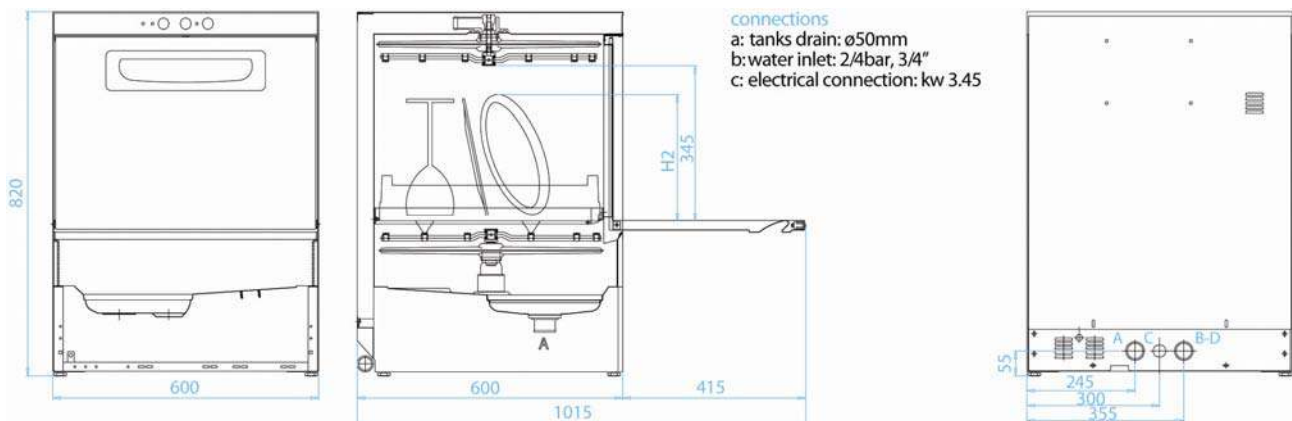

DIMENSIONS

Dishwasher: 600W x 600D x 820H mm

Clearance: 345 mm

Rack size: 500mm x 500mm

TECHNICAL DATA

Power Supply 240 Volts, 15amp

Total Output 3.45kW

Water Temp. Supply 45° - 55° C

Water Connection 2/4bar, 3/4"

Tanks Drain 50mm

Wash Cycle 120/180 seconds

Water Consumption 3.5L per cycle/rack

SPECIFICATIONS ARE SUBJECT TO CHANGE WITHOUT NOTICE.



www.comcater.com.au

PROUDLY DISTRIBUTED BY: