

500-1D/2D/3D Drawer Warmers



CE

Designed for both durability and exceptional food quality, Alto-Shaam's warming drawers seamlessly integrate into any kitchen layout where hot and fresh, ready-to-serve food needs to stay within easy reach. Featuring Halo Heat® technology, these drawers hold food at optimal serving temperatures without added water or harsh heating elements—preserving taste, texture, and freshness. Choose from flexible configurations: install in cabinets or counters, or stack units to make the most of your space.

Alto-Shaam's warming drawers feature a durable, non-magnetic, stainless steel exterior and removable stainless steel drawer rail supports. Each drawer includes one (1) GN 1/1 stainless steel pan—152mm deep. The unit is operated via an ON/OFF power switch and up and down arrow buttons on a digital display. It also includes a heat indicator light and a temperature display button.



Standard features

- Halo Heat...a controlled, uniform heat source that gently surrounds foods for better appearance, taste, and longer holding life.
- Product moisture is retained without adding water.
- Digital control senses temperature drops faster, providing quick heat recovery time.
- Can be built into cabinets or counters. Built-in trim kits are available.
- Stackable design.
- Vented for optimal moisture control.



Temperature range: 16°C to 93°C

TEMPERATURE



CAPACITY

Size	Pan Quantity	Product Weight per Drawer (kg)
500-1D	One (1) GN 1/1	16
500-2D	Two (2) GN 1/1	16
500-3D	Three (3) GN 1/1	16



ELECTRIC

Power Options and Cord/Plug Assemblies

NOTE: All cord/plug assemblies are 1.82M long.

230V

- 230V/50 Hz/1 Ph, CEE 7/7 5038471
- 230V/50 Hz/1 Ph, BS-1363 5038472
- 230V/50 Hz/1 Ph, CH2-16P 5038473
- 230V/50 Hz/1 Ph, AS/NZS 3112-2000 5038474
- 230V/50 Hz/1 Ph, TYPE M INI-16P 5038475



500-1D/2D/3D Drawer Warmers



DIMENSIONS

500-1D

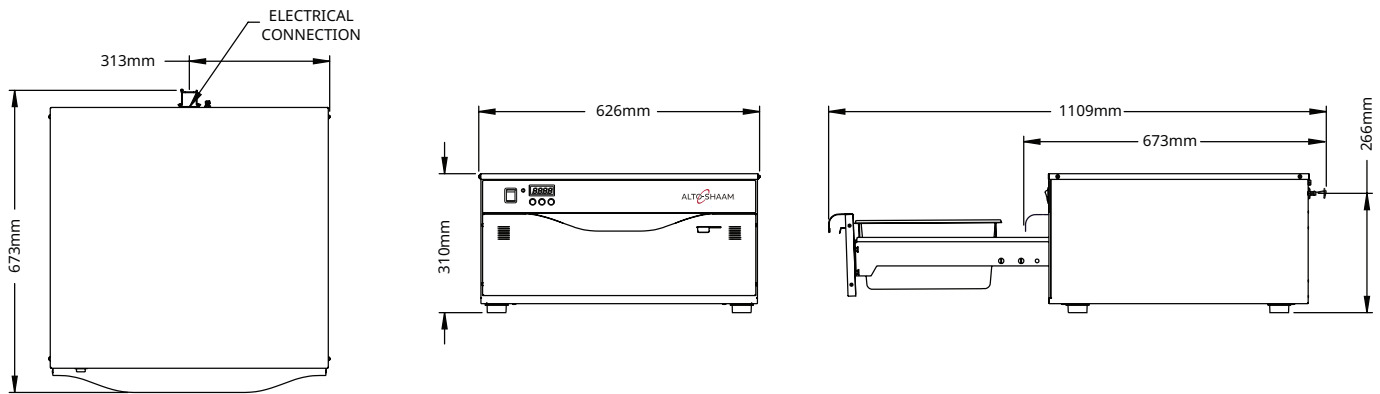

Shown with feet

500-2D

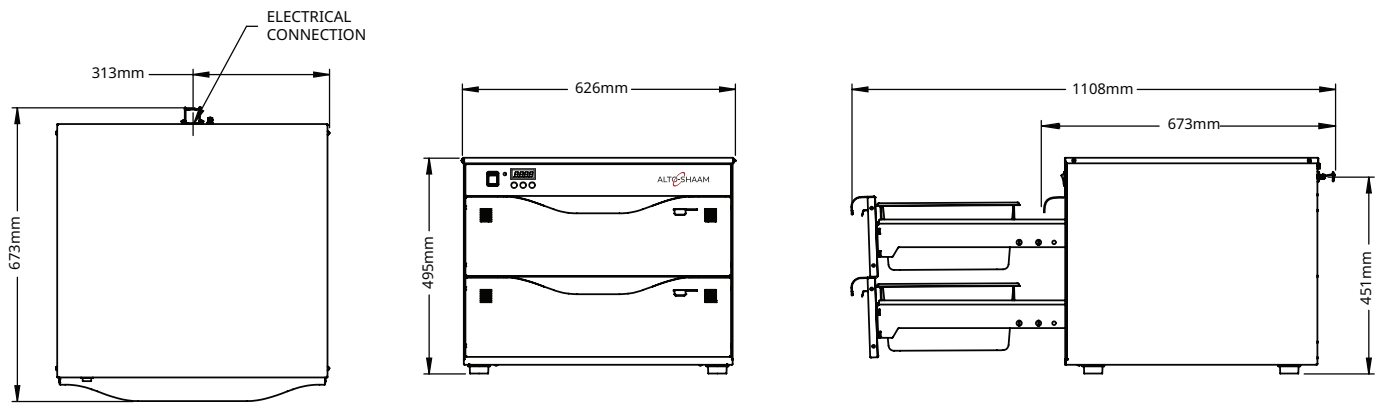

Shown with feet

500-3D

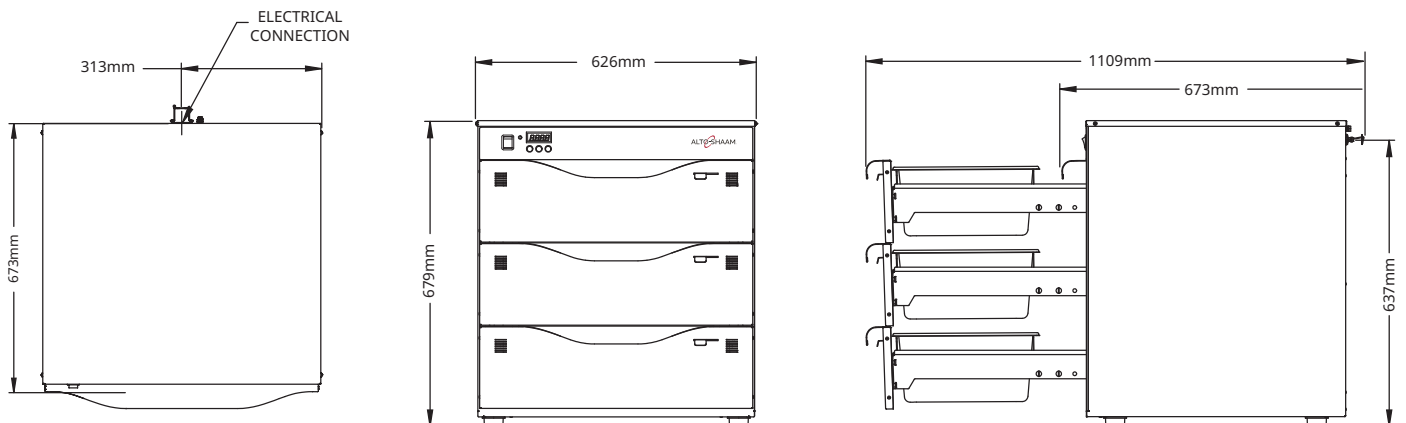

Shown with feet

500-1D/2D/3D Drawer Warmers

CUT-OUT DIMENSIONS

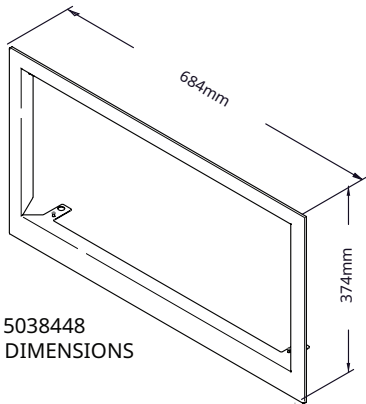

500-1D 5038448
TRIM KIT DIMENSIONS

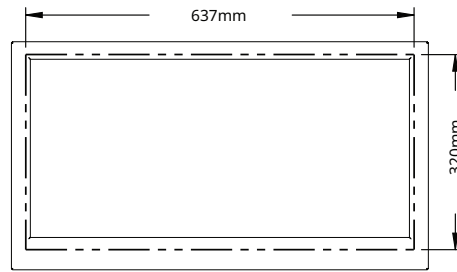

CUT-OUT DIMENSIONS

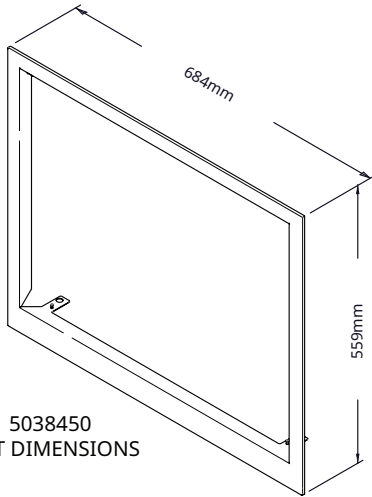

500-2D 5038450
TRIM KIT DIMENSIONS

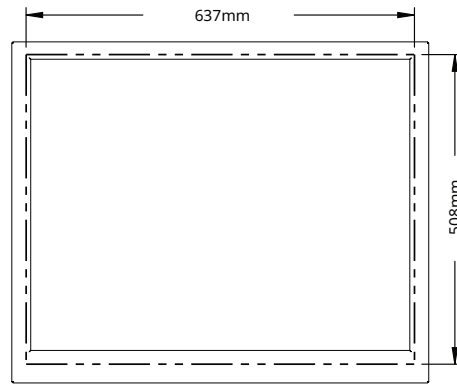

CUT-OUT DIMENSIONS

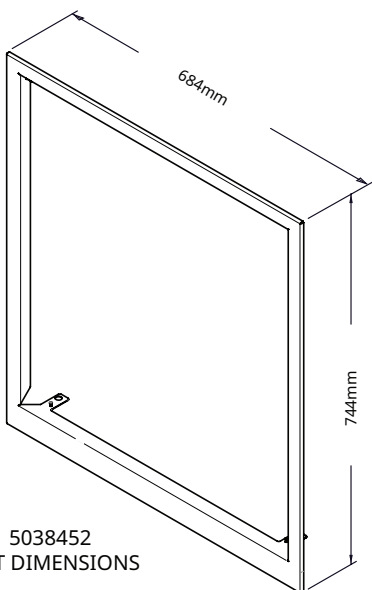

500-3D 5038452
TRIM KIT DIMENSIONS

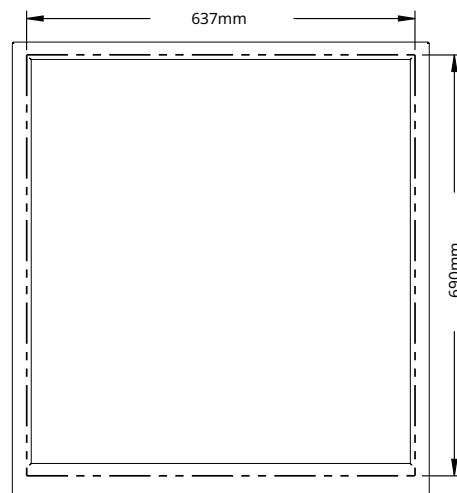

CUT-OUT DIMENSIONS

500-1D/2D/3D Drawer Warmers



CLEARANCE

Top:..... 51mm
 Left: 25mm
 Right:..... 25mm
 Back: 76mm



REQUIREMENTS

- Drawer warmer must be installed level.
- Drawer warmer must not be installed in any area where it may be affected by steam, grease, dripping water, extreme temperatures, or any other severely adverse conditions.

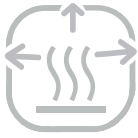

HEAT

Heat of rejection

	Heat Gain qs, BTU/hr	Heat Gain qs, kW
500-1D	262	0.08
500-2D	262	0.08
500-3D	262	0.08

Options and Accessories

- Perforated pan grid, 381mm x 508mm [1231]
- Perforated pan grid, 305mm x 508mm GNI/1 [16642]
- Wire grate, stainless 460mm x 254mm x 19mm [SH-47573]
- Wire grate, chrome 460mm x 254mm x 19mm [SH-47325]

Extended warranty

- One-year warranty extension



WEIGHTS

Size	Net Weight (est.)	Shipping Weight (est.)	Carton Dimensions (L x W x H)
500-1D	36 kg	41 kg	762mm x 686mm x 406mm
500-2D	52 kg	57 kg	762mm x 686mm x 584mm
500-3D	68 kg	75 kg	762mm x 686mm x 762mm



ELECTRIC

500-D/DN/DI	V	Ph	Hz	A	Breaker (A)	W
230V	230	1	50/60	2.6	15	590

Electrical connections must meet all applicable federal, state, and local codes.

CONTACT US

W164 N9221 Water Street | Menomonee Falls, Wisconsin 53051 | U.S.A.
 Phone: 262.251.3800 | 800.558.8744 U.S.A./Canada | Fax: 262.251.7067 | alto-shaam.com